

HID XENON

HEADLIGHTS

[Installation Guide]

Please read the installation guide carefully before removing original car lighting from the vehicle. Please read through the entire installation guide carefully before installing the HID system. Following this guide will make sure that no harm or damage comes to your vehicle.

1. As a safety precaution, make sure that the car has had time to cool down properly before starting the installation process.
2. Put the vehicle into "park" or make sure it is securely in gear.
3. Make sure to have the ignition turned off and the keys removed.
4. Be careful to avoid burns, especially when turning on or off the vehicle's lighting.
5. Be careful to avoid crushing or cutting the bulbs. Also make sure to not touch the bulbs with your fingers, as this will cause blotting.
6. Fully examine the connection of the contact points, ports and the wires as faulty connections can cause lighting problems.
7. Make certain that the end of the bulb does not come in contact with the interior light shield of the headlight when adjusting the bulb.
8. Some models required to drill a 25mm hole into the back of the resin or rubber headlight cap.

Method of installing the bulb and ballast.

1. Wrap the ballast tightly and make sure the two ends are firmly connected.
2. Connect the port of the bulb with the port of the power supply.

Please check on it after the installation.

1. Make sure that the wires are connected correctly and match up.
2. Also make sure to have the wires secured, but neither too loose nor too tight.
3. Be certain that there are no wires sticking out from the connection points.

Restoration of parts and the operation

1. Make sure that the parts taken apart for the installation are returned to their original places afterward.
2. Check on the effectiveness of the high beams and the low beams.
3. Always be sure to make sure that no other parts have been disturbed during the installation (lamps, wipers etc.).

Malfunction solutions

1. My lights installed but not turn on.

If you have installed your HID kit and nothing is happening then you will need to reverse the polarity. This means you will need to remove the plug that you plugged into the ballast and plug it in the opposite way.

2. HID lights turned on for couple seconds, then start flickering or one/both of the lights turn off.

The cars have onboard computers to restrict power to aftermarket HID conversion kit by sending unstable voltage to the ballast.

The solution is to install the HID kit with relay harness. The relay harness is to stabilize the voltage by getting power directly from battery.

3. Disable daytime running LL lights.

You may need to disable the daytime running lights for the installed HID headlight to work properly. To disable the daytime running lights, you may remove the daytime running lights fuse from the fuse box.

1. Parts Included In Kit

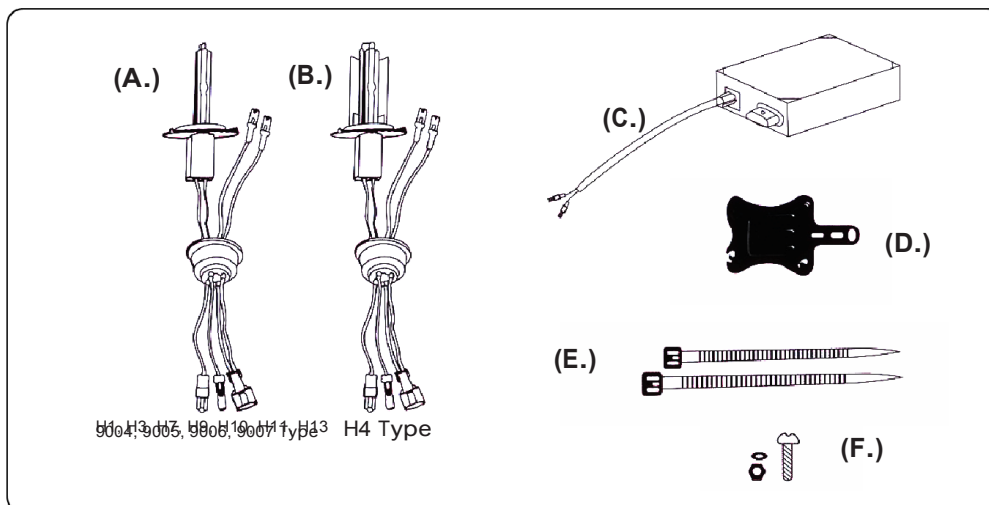

- (a/b) Xenon HID bulb x 2
- (c) Xenon HID ballast x 2
- (d) Bracket x 2 (Pre-installed to ballast)
- (e) Cable Ties
- (f) NNNNNNNN Bolts, nuts and gaskets

(Please make sure all parts are included in your HID Kit.)

2. Installation Process

(2a) Please open the hood and remove the headlight assemblies on both sides. If your engine bay has enough space for you to do the installation, the headlights may not have to be removed.

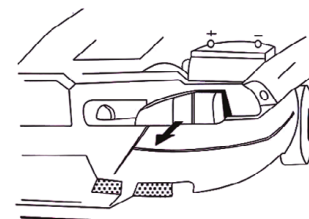

(2b) Remove the original bulb by opening up the back cap on the headlight assembly.

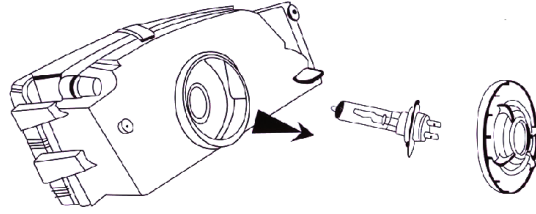

(2c) Remove the protection cap from the HID bulb.

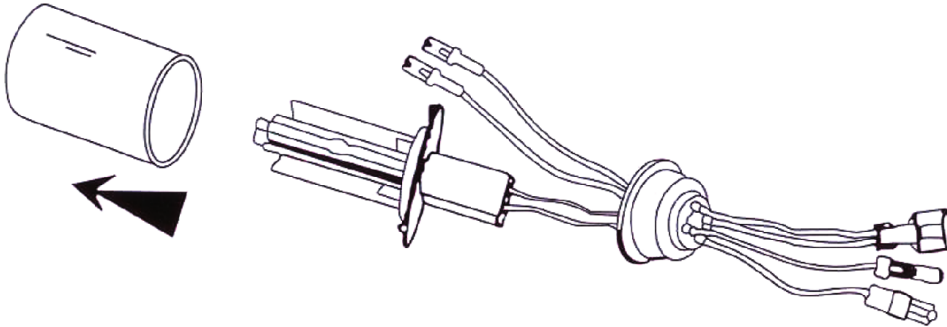

Notice.

- Please pay close attention to avoid any accidents during the installation.
- Do not touch the bulb with your fingers because it will leave blotting.
- Wearing gloves is a good idea, but if the bulb does become blotted, it is best to wipe it down with a dry Cloth or some rubbing alcohol.

***Lightly remove the plastic cap and do not hit the vacuum tube.**

(2d) Insert the HID bulb into the headlight housing.

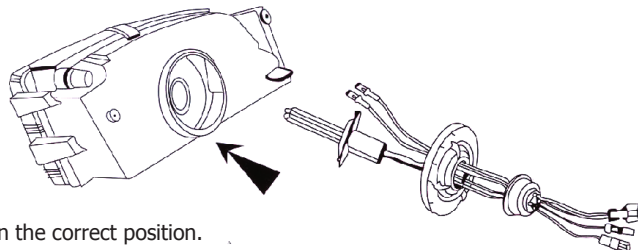

Notice. Please make sure the pressure spring is fixed in the correct position.

(2e) The following diagrams are of the installation of the power supply and the related information.

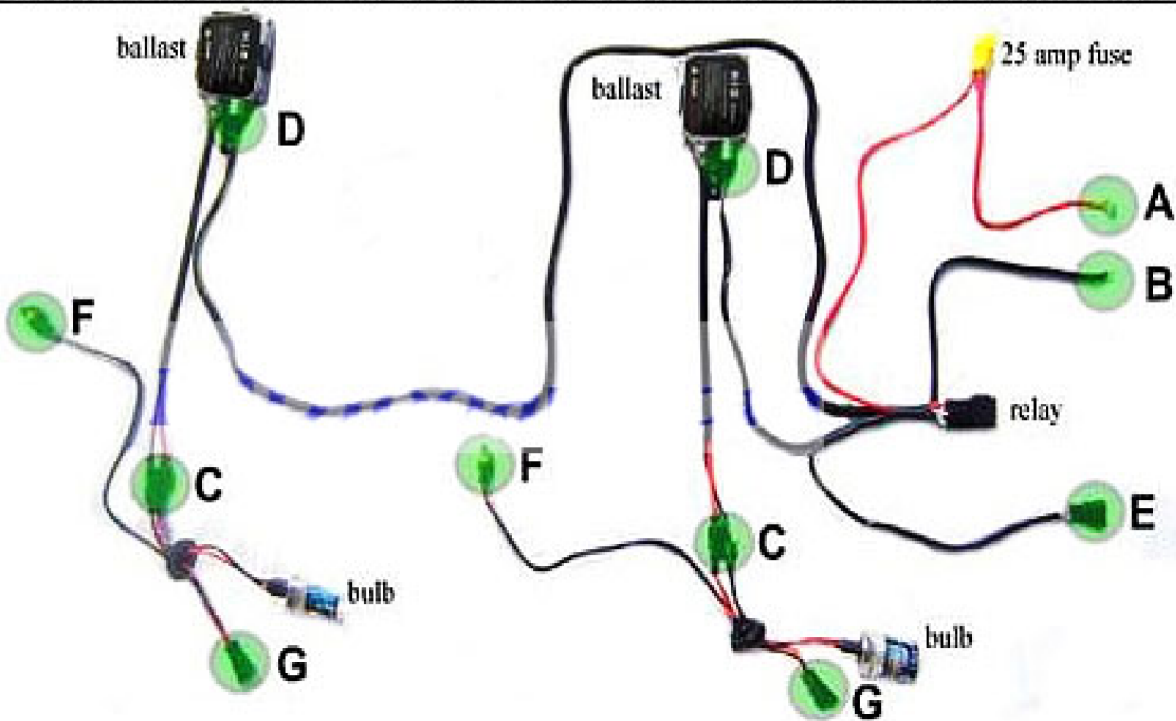

Installation with *relay harness*

- A - Positive + connect to the battery
- B - Ground - connect to the battery
- C - Ballast connection to the HID bulbs
- D - Relay harness connection to the ballasts (short wire + long wire)
- E - Plug directly to the cars OEM wire harness (plug from the halogen bulb)

Installation with *plug and play wires*

- C - Ballast connection to the HID bulbs
- F - Connection to the ballasts (same as D)
- G - Plug directly to the cars OEM wire harness (plug from the halogen bulb)

(2f) Begin by plugging the wiring harness into the rubber base and then fitting the back cap onto the assembly. When finished, close the headlight shield tightly.

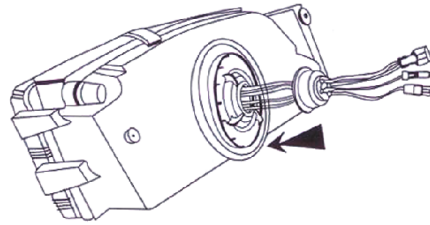
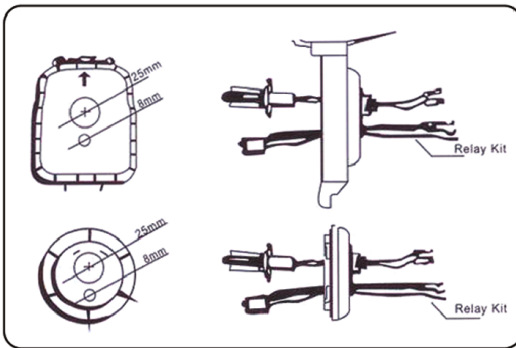
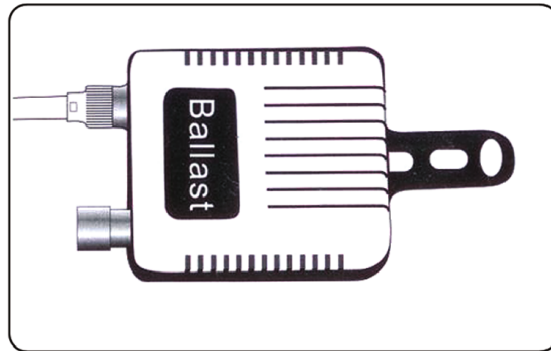
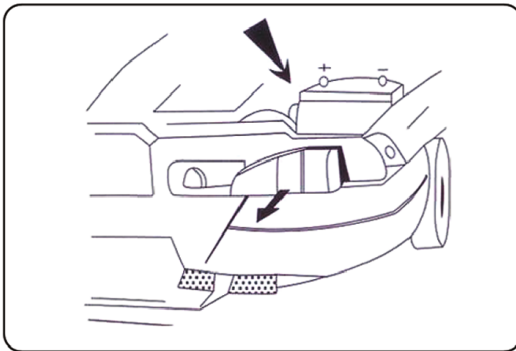

Figure 2f.

(2g) affix the ballast to any solid place in the engine bay by using double-sided tape, brackets or zip ties. (Avoid areas where high temperatures can build up.)



Please refer to the drawing on the left when running the relay

1. Drill holes with the 25mm cutter and an 8mm drill in the middle of the back side of the headlight cup. Make sure that the 25mm hole is above the 8mm hole to be able to install the relay and bulb as easily as possible.

2. As shown in the first drawing, insert the wire of the relay and then put the rubber base into the 8mm hole in the back of the headlight.

Figure 2g.

(2h) Connect the ballast wiring harness to the wiring harness of the bulb.

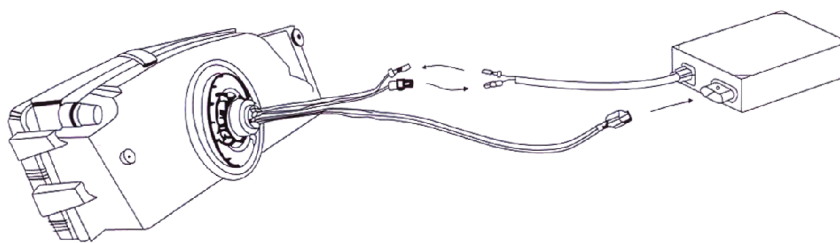
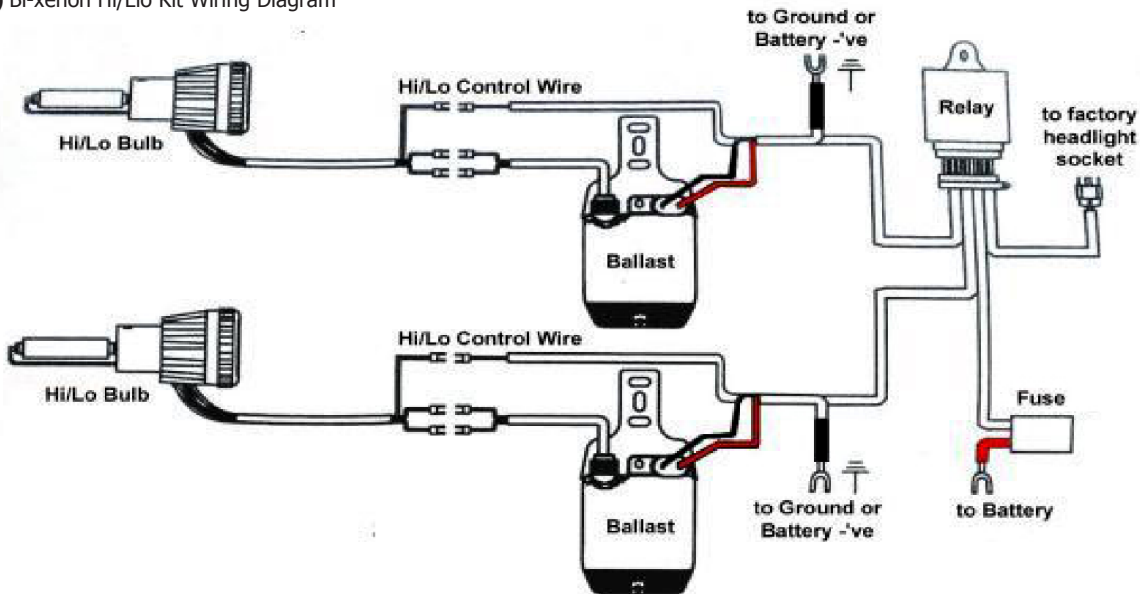

Figure 2h.

Notice. Make sure connect to the correct positive and negative wires; also a click sound implies successful connection

3. Hi/Lo Bulb

(3a) Bi-xenon Hi/Llo Kit Wiring Diagram



- Be sure to read all the instructions before installation.
- Make certain to check the power supply before installing the Hi/Lo light system.
- Adjust the positive and negative wires accordingly before you begin.
- Do not use too much pressure when extracting or installing the bulbs, as this may result in damage to the lights.

Figure 3a.

NOTICE

1. Take care! High voltage is dangerous! It may cause harm with electric shocks.
2. Do not touch the bulbs when turning the power on and off. The heat released may end up scalding you.
3. Do not stare directly at the light bulbs themselves as this can cause serious damage to your eyes.
4. In case of an accident, turn the power supply off. Broken voltage boxes and wires are dangerous and can cause injury.
5. Do not attempt to disassemble or reconstruct broken parts. If such actions are attempted, we take no responsibilities for the results.
6. If repairs or replacements are needed, seek out the nearest specialized shop to help you out.
7. Keep these products away from flammable objects such as, but not limited to: paper, oil, spray paint, diluting agents, etc.
8. Do not adjust the lights to point upward. Doing so can seriously impair other drivers on the road and will be detrimental to their safety.
9. Please do not switch on the lights until the vehicle has been started.

Getting Technical Support and Service

Xenon Kit has no field-service parts. Opening it will **VOID WARRANTY**.

Dip heavy machinery limited can and will service your HID kit . If you are expecting problem with it, please contact:

Dip Heavy Machinery Limited

Support department

Phone : 230 58 63 8500

Email : support@dipparts.com



dip Genuine Xenon Kit come with
6 months Warrantee from the date of purchase